



# ICE CREAM FACTORY



# 6450-C

## FROZEN BEVERAGE FREEZER

Single flavor, Countertop, Gravity feed

Most **Compact & Versatile**  
Single flavor counter model for  
frozen beverages



### Fast Freeze Down

Patented high efficiency heat exchanger allows fast freeze down with low energy consumption

### Simple Control, Easy Operation

Simple and intuitive control system makes operation and viscosity adjustment easy, swift and more precise

### Low Mix Indicator

Light turns "ON" at low mix to alert operator to add mix

### Safety Protections

- High pressure switch to prevent compressor overheating
- Thermal overload to protect from motor overheating

### See-through Dispensing Door

Clear dispensing door design makes product more attractive and serves as great marketing tool

### Self-closing Dispensing Valve

Automatically prevents product overflow after dispense

Perfect solution for alcoholic and non-alcoholic  
frozen beverages in bars and restaurants





## 6450-C

## FROZEN BEVERAGE FREEZER

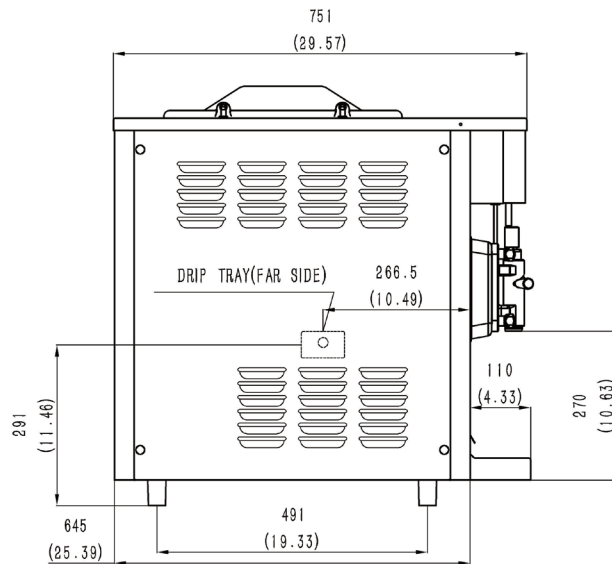
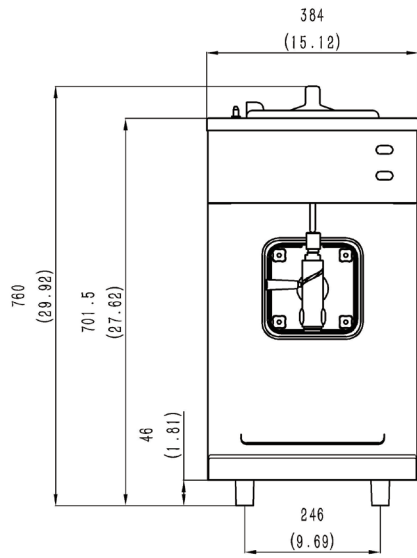

### SPECIFICATIONS

Flavors	1
Freezing Cylinders	1x 3.8L / 4.0qt
Mix Hoppers	1x 12L / 12.7qt
Output Capacity (8oz)	90 servings/hr
Clearance Requirements	152mm/6"

### Weight                      Kg/lb

Net	99 / 220
Shipping	109 / 242
Volume	0.29 CBM / 10.13 CBF

### Dimensions              Net (mm/in)              Shipping (mm/in)

Width	384 / 15.1	420 / 16.5
Depth	645 / 25.4	770 / 30.3
Height	760 / 29.9	890 / 35.0

### Electrical              FLA              Power(kW)              Plug

110-120/60/1	10	1.0	5-20P
--------------	----	-----	-------

### FEATURES

Control System	One, Mechanical
Auto Closing Dispensing Valve	✓
Low Mix Indicator Light	✓
High Pressure Protection	✓
Thermal Overload Protection	✓

• Above specifications are subject to change without notice